

SC5-5.5

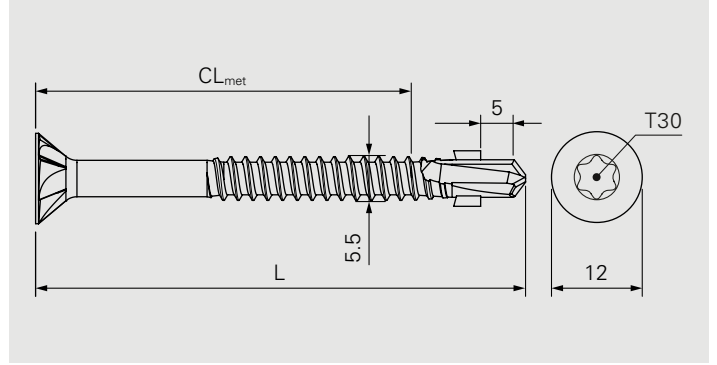
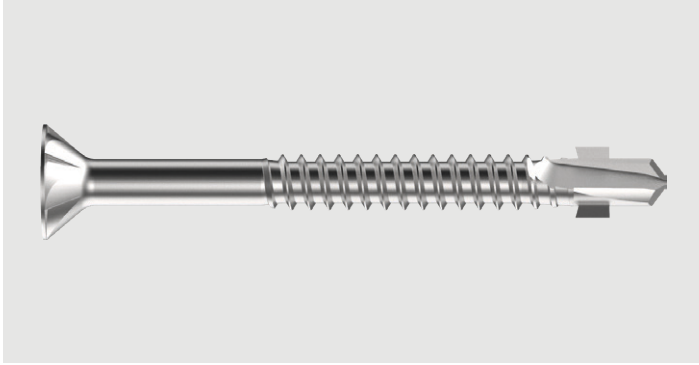

Application

Fastening of timber boards onto supporting steel structures

Component 1 (t_I)

Timber

Component 2 (t_{II})

Steel

1.75–5.0

$\Sigma_{\max} t_{II}$

5.0

Fastener material

Carbon steel, zinc coated 500 h NSS

Approvals

–

Features and Benefits

- Flush-mounted installation without damaging the timber surface given by the milling grooves
- Ergonomical setting tool available

All measures in mm

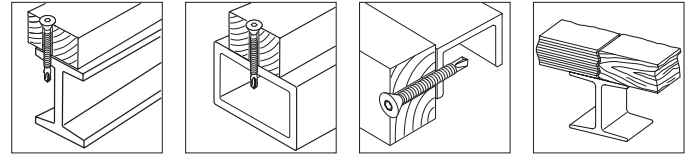

Fastener in carbon steel onto steel

Product code	PU	L	CL _{met}	
SC5/46-12CC-5,5×60	1000	60	25-46	1580102

$t_{fix, met} = CL_{met, min.} - (CL_{met, max.} - t_{II, max.})$ or load-bearing clamping length according ETA)/($CL_{met, max.} - t_{II, min.}$)

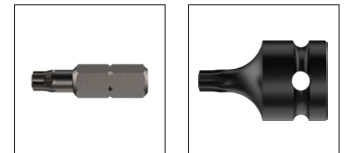

Accessories/Ancillaries

Product code	PU	Drive	Head drive	
T30-25-HEX $\frac{1}{4}$ "	1	$\frac{1}{4}$ "	T30	1690315
TX30-35HEX $\frac{1}{2}$ "		$\frac{1}{2}$ "		1690314

All measures in mm

All information is non-binding and without guarantee. Before using the products, all specifications and calculations must be checked by a suitably qualified person and local regulations must be observed. This document is subject to revision. We reserve the right to make technical changes.