

SD6-H15-E11-5.5

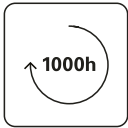
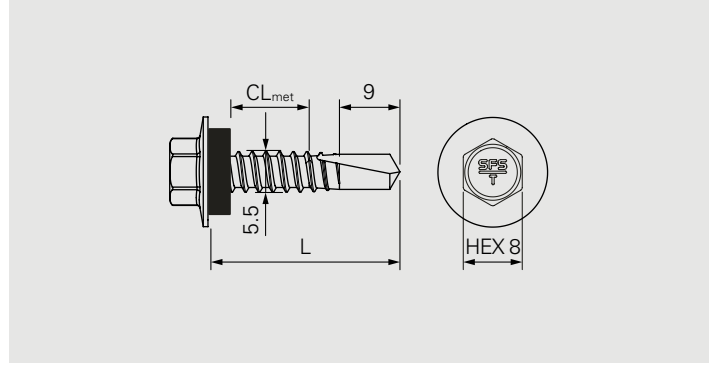

Application

Fastening of metal decks, liner trays onto metal profiles

Component 1 (t_I)

Steel

0.50–1.50

Component 2 (t_{II})

Steel

1.50–5.0

$\Sigma_{\max} t_I + t_{II}$

6.0

–

–

Steel

2×1.50–3.0

7.0

Fastener material

Carbon steel, Durocoat® 1000

Approvals



Features and Benefits

- Self drilling fastener suitable for installation of metal decks and liner trays
- Reduced risks of over driving by a cone under the head and the deformation of the EPDM ring
- High shear resistance achieved by optimized fastener geometry
- High corrosion durability thanks to high-tech zinc flaces coating

Documentation

Approval document (ETA) | Declaration of performance (DoP)

All measures in mm

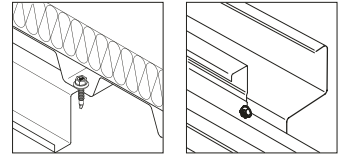

Fastener in carbon steel onto steel

Product code	PU	L	CL _{met}	t _{fix, met}	
SD6-H15-E11-5,5×22	500	22	0-8	0-6/7	1769390

t_{fix, met}: CL_{met, min.} - (CL_{met, max.} - t_{II, max.} or load-bearing clamping length according ETA)/(CL_{met, max.} - t_{II, min.})

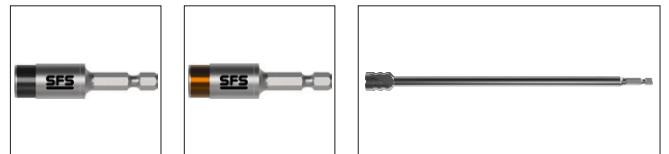

Accessories/Ancillaries

Product code	PU	Drive	Head drive	
SOK-IT-¼"-57-6Nm	1	¼"	SW8	1667323
SOK-IT-¼"-57-8Nm				1667322
Drive shaft H15 head	5		H15	1517546

All measures in mm

All information is non-binding and without guarantee. Before using the products, all specifications and calculations must be checked by a suitably qualified person and local regulations must be observed. This document is subject to revision. We reserve the right to make technical changes.